

**IN THE UNITED STATES DISTRICT COURT
FOR THE NORTHERN DISTRICT OF ILLINOIS
EASTERN DIVISION**

DYSON TECHNOLOGY LIMITED,

Plaintiff,

v.

THE PARTNERSHIPS AND
UNINCORPORATED ASSOCIATIONS
IDENTIFIED ON SCHEDULE “A,”

Defendants.

Case No. 26-cv-01095

COMPLAINT

Plaintiff Dyson Technology Limited (“Dyson” or “Plaintiff”) hereby brings the present action against the Partnerships and Unincorporated Associations identified on Schedule A attached hereto (collectively, “Defendants”) and alleges as follows:

I. JURISDICTION AND VENUE

1. This Court has original subject matter jurisdiction over the claims in this action pursuant to the provisions of the Patent Act, 35 U.S.C. § 1, *et seq.*, 28 U.S.C. § 1338(a)-(b) and 28 U.S.C. § 1331.

2. Venue is proper in this Court pursuant to 28 U.S.C. § 1391, and this Court may properly exercise personal jurisdiction over Defendants since each of the Defendants directly targets business activities toward consumers in the United States, including Illinois, through at least the fully interactive, e-commerce stores¹ operating under the seller aliases identified in Schedule A attached hereto (the “Seller Aliases”). Specifically, Defendants have targeted sales to

¹ The e-commerce store urls are listed on Schedule A hereto under the Online Marketplaces.

Illinois residents by setting up and operating e-commerce stores that target United States consumers using one or more Seller Aliases, offer shipping to the United States, including Illinois, accept payment in U.S. dollars from U.S. consumers, and, on information and belief, have sold products featuring Dyson's patented design to residents of Illinois. Each of the Defendants is committing tortious acts in Illinois, is engaging in interstate commerce, and has wrongfully caused Dyson substantial injury in the State of Illinois.

II. INTRODUCTION

3. This action has been filed by Dyson to combat e-commerce store operators who trade upon Dyson's reputation and goodwill by making, using, offering for sale, selling and/or importing into the United States for subsequent sale or use the same unauthorized and unlicensed product, namely the battery pack shown in **Exhibit 1**, that infringes Dyson's patented design, U.S. Patent No. D710,299 (the "Infringing Products"). Defendants create e-commerce stores operating under one or more Seller Aliases that are making, using, offering for sale, selling, and/or importing into the United States for subsequent sale or use Infringing Products to unknowing consumers. Defendants' activities, occurring at the same time and in the same retail space and manner as one another, blend together to create a single negative impression on consumers such that they constitute the same occurrence or series of occurrences. Defendants attempt to avoid and mitigate liability by operating under one or more Seller Aliases to conceal both their identities and the full scope and interworking of their operation. Dyson has filed this action to combat Defendants' infringement of its patented design, as well as to protect unknowing consumers from purchasing Infringing Products over the Internet. Dyson has been and continues to be irreparably damaged from the loss of its lawful patent rights to exclude others from making, using, selling, offering for

sale, and importing its patented design as a result of Defendants' actions and seeks injunctive and monetary relief.

III. THE PARTIES

Plaintiff Dyson

4. Plaintiff Dyson Technology Limited is a limited company having its principal place of business at Tetbury Hill, Malmesbury, Wiltshire, United Kingdom, SN16 0RP.

5. Founded in the United Kingdom 1991, Dyson is a world-famous technology company that designs, manufactures and distributes corded vacuums, cordless vacuums and accessories for the same, including battery packs for such products, as well as a variety of other products (collectively, the "Dyson Products"). Dyson Products can be purchased in over 65 countries around the world. Since at least January 2002, Dyson (or one of its group companies) has marketed, advertised, promoted, distributed and sold Dyson Products to consumers in the United States. Dyson Products have become enormously popular and even iconic, driven by Dyson's arduous quality standards and Dyson Products' unique and innovative design. As a result, among the purchasing public, genuine Dyson Products are instantly recognizable as such. In the United States and around the world, the Dyson brand has come to symbolize high quality, and Dyson Products are among the most recognizable products in the world.

6. Dyson vacuums are distributed and sold online to consumers through retailers throughout the United States, including through authorized retailers in Illinois, the official [dyson.com/en](https://www.dyson.com/en) website, and various authorized retail channels including Walmart, Nordstrom, Best Buy, Ulta Beauty, and Sephora.

7. Dyson machines are also promoted and sold offline, in traditional bricks and mortar retail premises, including at “Dyson Demo Store” retail premises (including in New York City, San Francisco, Los Angeles, Santa Clara and Tysons Corner, VA).

8. Dyson Products are known for their distinctive patented designs. These designs are broadly recognized by consumers. Dyson Products, namely, battery packs, styled after these designs are associated with the quality and innovation that the public has come to expect from Dyson Products. Dyson uses these designs in connection with its Dyson Products, including, but not limited to, the patented design shown in the below table, herein referred to as the “Dyson Design.” Dyson Products, including those which embody the Dyson Design, are marked in compliance with 35 U.S.C. § 287(a).

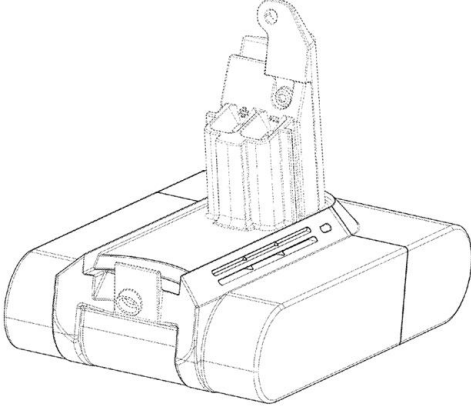
Patent Number	Claim	Issue Date
D710,299	 <p data-bbox="743 1455 808 1482">FIG. 1</p>	August 5, 2014

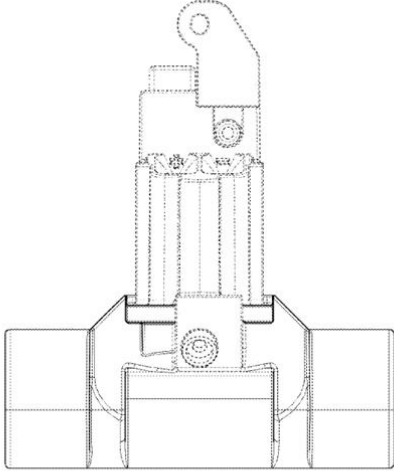
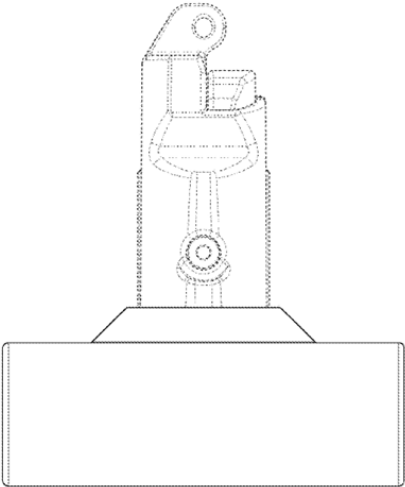
Patent Number	Claim	Issue Date
	 <p data-bbox="737 816 824 848">FIG. 2</p>  <p data-bbox="725 1453 813 1484">FIG. 3</p>	

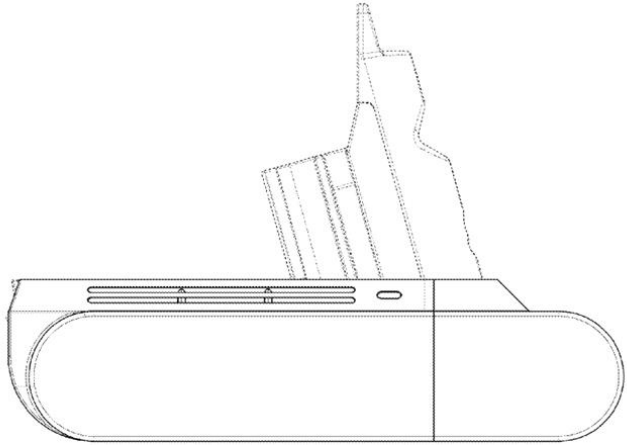
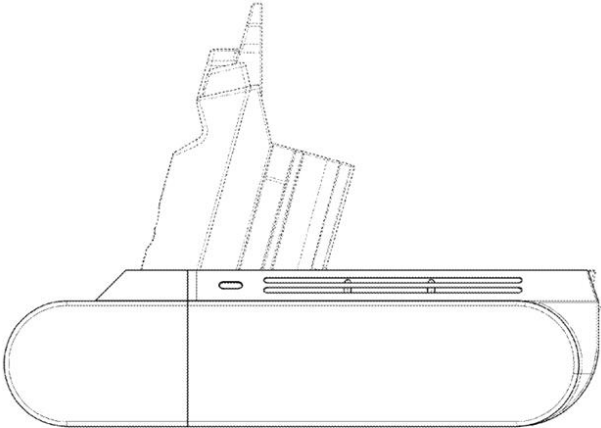
Patent Number	Claim	Issue Date
	 <p data-bbox="727 772 813 806">FIG. 4</p>  <p data-bbox="727 1346 813 1379">FIG. 5</p>	

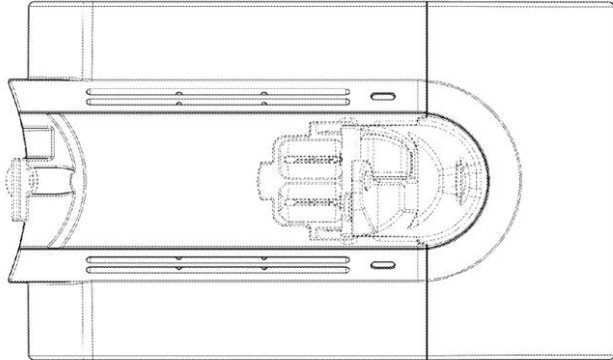
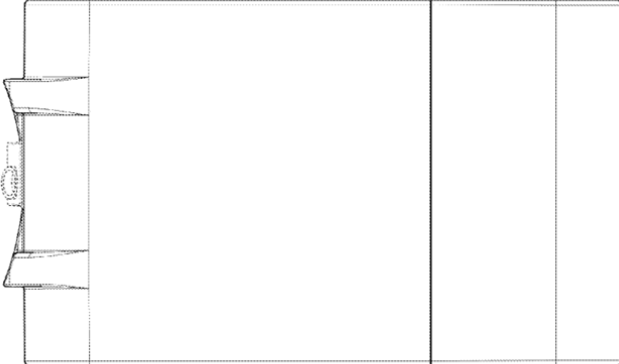
Patent Number	Claim	Issue Date
	 <p data-bbox="721 697 808 730">FIG. 6</p>  <p data-bbox="737 1205 824 1239">FIG. 7</p>	

9. Dyson is the lawful assignee of all right, title, and interest in and to the Dyson Design. The D710,299 patent for the Dyson Design was lawfully issued on August 5, 2014, with named inventors: James Dyson, Peter David Gammack, Timothy Nicholas Stickney, and Jonathan George Marsh. Attached hereto as **Exhibit 2** is a true and correct copy of the United States Patent for the Dyson Design.

The Defendants

10. Defendants are individuals and business entities of unknown makeup who own and/or operate one or more of the e-commerce stores under at least the Seller Aliases identified on

Schedule A and/or other seller aliases not yet known to Dyson. On information and belief, Defendants reside and/or operate in the People's Republic of China or other foreign jurisdictions with lax intellectual property enforcement systems, or redistribute products from the same or similar sources in those locations. Defendants have the capacity to be sued pursuant to Federal Rule of Civil Procedure 17(b).

11. On information and belief, Defendants either individually or jointly, operate one or more e-commerce stores under the Seller Aliases listed in Schedule A attached hereto. Tactics used by Defendants to conceal their identities and the full scope of their operation make it virtually impossible for Dyson to discover Defendants' true identities and the exact interworking of their network. If Defendants provide additional credible information regarding their identities, Dyson will take appropriate steps to amend the Complaint.

IV. DEFENDANTS' UNLAWFUL CONDUCT

12. In recent years, Dyson has identified numerous fully interactive, e-commerce stores, including those operating under the Seller Aliases, which were offering for sale and/or selling Infringing Products on online marketplace platforms such as Amazon, eBay, Temu and Walmart, including the e-commerce stores operating under the Seller Aliases. The Seller Aliases target consumers in this Judicial District and throughout the United States. At last count, global trade in counterfeit and pirated goods was worth an estimated \$467 billion per year — accounting for a staggering 2.3% of all imports, according to the Organization for Economic Cooperation and

Development (the “OECD”).² The primary source of all those counterfeits, the OECD and others say, is China.³

13. Third party service providers like those used by Defendants do not adequately subject new sellers to verification and confirmation of their identities, allowing infringers to “routinely use false or inaccurate names and addresses when registering with these e-commerce platforms.”⁴ Infringers hedge against the risk of being caught and having their websites taken down from an e-commerce platform by preemptively establishing multiple virtual storefronts.⁵ Since platforms generally do not require a seller on a third-party marketplace to identify the underlying business entity, infringers can have many different profiles that can appear unrelated even though they are commonly owned and operated.⁶ Further, “E-commerce platforms create bureaucratic or technical hurdles in helping brand owners to locate or identify sources of [infringement].”⁷

14. Defendants have targeted sales to Illinois residents by setting up and operating e-commerce stores that target United States consumers using one or more Seller Aliases, offer

² See Press Release, Organization for Economic Cooperation and Development, *Global trade in fake goods reached USD 467 billion, posing risks to consumer safety and compromising intellectual property* (May 7, 2025), <https://www.oecd.org/en/about/news/press-releases/2025/05/global-trade-in-fake-goods-reached-USD-467-billion-posing-risks-to-consumer-safety-and-compromising-intellectual-property.html>.

³ *Id.*; See also, *Intellectual Property Rights Seizure Statistics, Fiscal Year 2024*, U.S. Customs and Border Protection.

⁴ See Daniel C.K. Chow, *Alibaba, Amazon, and Counterfeiting in the Age of the Internet*, 40 NW. J. INT’L L. & BUS. 157, 186 (2020); see also report on “Combating Trafficking in Counterfeit and Pirated Goods” prepared by the U.S. Department of Homeland Security’s Office of Strategy, Policy, and Plans (Jan. 24, 2020), and finding that on “at least some e-commerce platforms, little identifying information is necessary for a counterfeiter to begin selling” and recommending that “[s]ignificantly enhanced vetting of third-party sellers” is necessary.

⁵ *Id.* at 22.

⁶ *Id.* at 39.

⁷ Chow, *supra* note 4, at 186-87.

shipping to the United States, including Illinois, accept payment in U.S. dollars from U.S. consumers, and, on information and belief, have sold Infringing Products to residents of Illinois.

15. Defendants concurrently employ and benefit from substantially similar advertising and marketing strategies. For example, Defendants facilitate sales by designing e-commerce stores operating under the Seller Aliases so that they appear to unknowing consumers to be authorized online retailers, outlet stores, or wholesalers. E-commerce stores operating under the Seller Aliases appear sophisticated and accept payment in U.S. dollars from U.S. consumers. E-commerce stores operating under the Seller Aliases often include content and images that make it very difficult for consumers to distinguish such stores from an authorized retailer. Dyson has not licensed or authorized Defendants to use the Dyson Design, and none of the Defendants are authorized retailers of genuine Dyson Products.

16. E-commerce store operators like Defendants commonly engage in fraudulent conduct when registering the Seller Aliases by providing false, misleading and/or incomplete information to e-commerce platforms to prevent discovery of their true identities and the scope of their e-commerce operation.

17. E-commerce store operators like Defendants regularly register or acquire new seller aliases for the purpose of offering for sale and selling Infringing Products. Such seller alias registration patterns are one of many common tactics used by e-commerce store operators like Defendants to conceal their identities and the full scope and interworking of their operation, and to avoid being shut down.

18. Defendants are collectively causing harm to Plaintiff's goodwill and reputation because the effect of their unlawful actions taken together amplifies each harm and creates a single negative consumer impression. Defendants' activities, occurring at the same time and in the same

retail space and manner as one another, blend together to create a single negative impression on consumers such that they constitute the same occurrence or series of occurrences. The combination of all Defendants engaging in the same illegal activity in the same time span causes a collective harm to Plaintiff in a way that individual actions, occurring alone, might not.

19. E-commerce store operators like Defendants are in constant communication with each other and regularly participate in QQ.com chat rooms and through websites such as sellerdefense.cn and kuajingvs.com regarding tactics for operating multiple accounts, evading detection, pending litigation, and potential new lawsuits.

20. Infringers such as Defendants typically operate under multiple seller aliases and payment accounts so that they can continue operation in spite of Dyson's enforcement. E-commerce store operators like Defendants maintain off-shore bank accounts and regularly move funds from their financial accounts to off-shore accounts outside the jurisdiction of this Court to avoid payment of any monetary judgment awarded to Dyson. Indeed, analysis of financial account transaction logs from previous similar cases indicates that off-shore infringers regularly move funds from U.S.-based financial accounts to off-shore accounts outside the jurisdiction of this Court.

21. Defendants are working to knowingly and willfully import, distribute, offer for sale, and sell Infringing Products in the same transaction, occurrence, or series of transactions or occurrences. Defendants, without any authorization or license from Dyson, have knowingly and willfully offered for sale, sold, and/or imported into the United States for subsequent resale or use the same product that infringes directly and/or indirectly the Dyson Design. Each e-commerce store operating under the Seller Aliases offers shipping to the United States, including Illinois,

and, on information and belief, each Defendant has sold Infringing Products into the United States and Illinois over the Internet.

22. Defendants' infringement of the Dyson Design in the making, using, offering for sale, selling, and/or importing into the United States for subsequent sale or use of the Infringing Products was willful.

23. Defendants' infringement of the Dyson Design in connection with the making, using, offering for sale, selling, and/or importing into the United States for subsequent sale or use of the Infringing Products, including the making, using, offering for sale, selling, and/or importing into the United States for subsequent sale or use of Infringing Products into Illinois, is irreparably harming Dyson.

COUNT I
INFRINGEMENT OF UNITED STATES DESIGN PATENT NO. D710,299
(35 U.S.C. § 271)

24. Dyson hereby re-alleges and incorporates by reference the allegations set forth in the preceding paragraphs.

25. Defendants are making, using, offering for sale, selling, and/or importing into the United States for subsequent sale or use Infringing Products that infringe directly and/or indirectly the ornamental design claimed in the Dyson Design.

26. Defendants have infringed the Dyson Design through the aforesaid acts and will continue to do so unless enjoined by this Court. Defendants' wrongful conduct has caused Dyson to suffer irreparable harm resulting from the loss of its lawful patent rights to exclude others from making, using, selling, offering for sale, and importing the patented invention. Dyson is entitled to injunctive relief pursuant to 35 U.S.C. § 283.

27. Dyson is entitled to recover damages adequate to compensate for the infringement, including Defendants' profits pursuant to 35 U.S.C. § 289. Dyson is entitled to recover any other damages as appropriate pursuant to 35 U.S.C. § 284.

PRAYER FOR RELIEF

WHEREFORE, Dyson prays for judgment against Defendants as follows:

- 1) That Defendants, their affiliates, officers, agents, servants, employees, attorneys, confederates, and all persons acting for, with, by, through, under or in active concert with them be temporarily, preliminarily, and permanently enjoined and restrained from:
 - a. making, using, offering for sale, selling, and/or importing into the United States for subsequent sale or use the Infringing Products;
 - b. aiding, abetting, contributing to, or otherwise assisting anyone in making, using, offering for sale, selling, and/or importing into the United States for subsequent sale or use the Infringing Products; and
 - c. effecting assignments or transfers, forming new entities or associations or utilizing any other device for the purpose of circumventing or otherwise avoiding the prohibitions set forth in Subparagraphs (a) and (b).
- 2) Entry of an Order that, upon Dyson's request, those with notice of the injunction, including, without limitation, any online marketplace platforms such as Amazon, eBay, Temu and Walmart (collectively, the "Third Party Providers") shall disable and cease displaying any advertisements used by or associated with Defendants in connection with the sale of the Infringing Products;
- 3) That Dyson be awarded such damages as it shall prove at trial against Defendants that are adequate to compensate Dyson for Defendants' infringement of the Dyson Design, but in no

event less than a reasonable royalty for the use made of the invention by the Defendants, together with interest and costs, pursuant to 35 U.S.C. § 284;

- 4) That the amount of damages awarded to Dyson to compensate Dyson for infringement of the Dyson Design be increased by three times the amount thereof, as provided by 35 U.S.C. § 284;
- 5) In the alternative, that Dyson be awarded all profits realized by Defendants from Defendants' infringement of the Dyson Design, pursuant to 35 U.S.C. § 289;
- 6) That Dyson be awarded its reasonable attorneys' fees and costs; and
- 7) Award any and all other relief that this Court deems just and proper.

Dated this 30th day of January 2026.

Respectfully submitted,

/s/ Justin R. Gaudio

Justin R. Gaudio

Justin T. Joseph

Lucas A. Peterson

Greer, Burns & Crain, Ltd.

200 West Madison Street, Suite 2100

Chicago, Illinois 60606

312.360.0080

312.360.9315 (facsimile)

jgaudio@gbc.law

jjoseph@gbc.law

lpeterson@gbc.law

Counsel for Plaintiff Dyson Technology Limited